

# Techna STRAIGHTENERS (WIRE & STRIP)

## DW - Cassette Style Straightener with Quick-Closing

For high speed, heavy duty applications e.g. high speed extrusion at 600m/min.

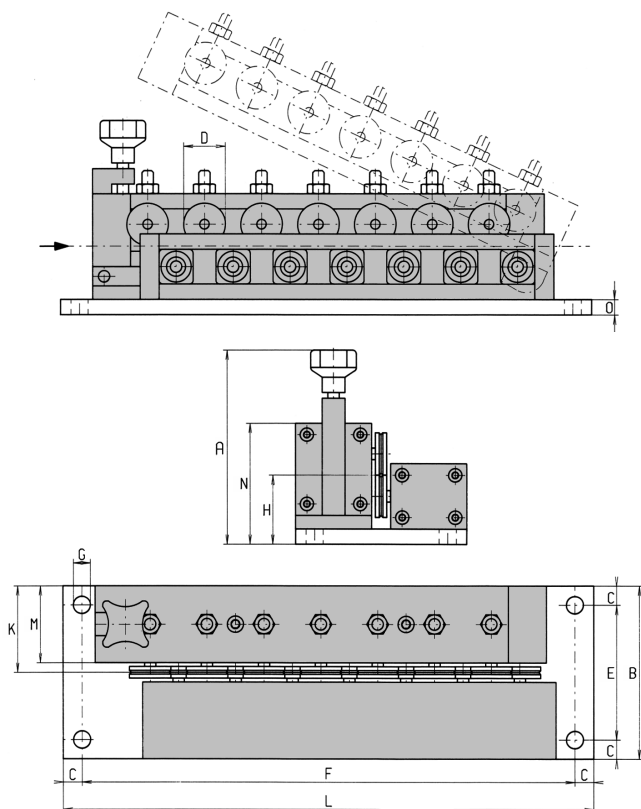
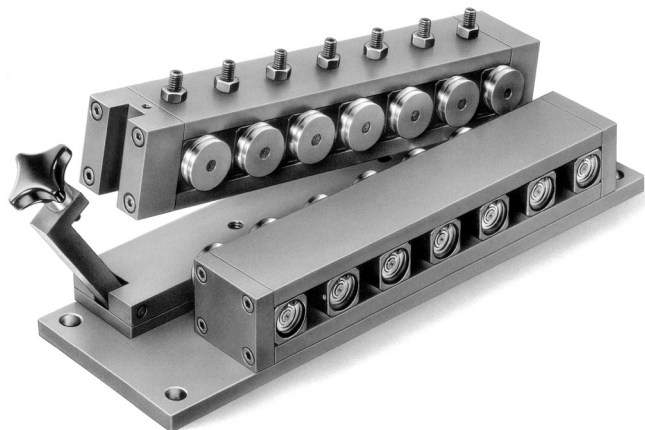

DW Series	Wire Diameter Ranges (mm) $\phi$			
	0.1 - 0.4	0.2 - 0.5	0.5 - 0.8	0.8 - 1.5
Order Ref.	DW14-0.4	DW14-0.5	DW14-0.8	DW14-1.5
A	123.5	123.5	126	131
B	90	90	90	90
C	10	10	10	10
D	9	13	17	22
E	70	70	70	70
F	200	212	233	275
G	9	9	9	9
H	43.5	41	41.5	44
K	45	45	45	45
L	220	232	253	295
M	40	40	40	40
N	65	65	68	73
O	8	8	8	8
Kg	4.8	5	5.5	7

## HR - Helix Straightener®

With vertically and horizontally adjustable centre roll for removing or inducing helical cast in one operation.

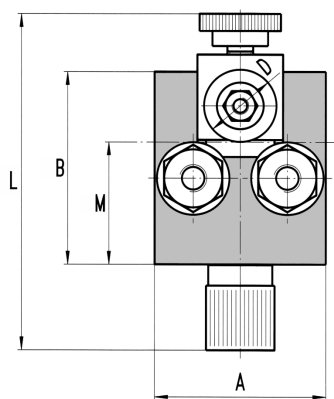
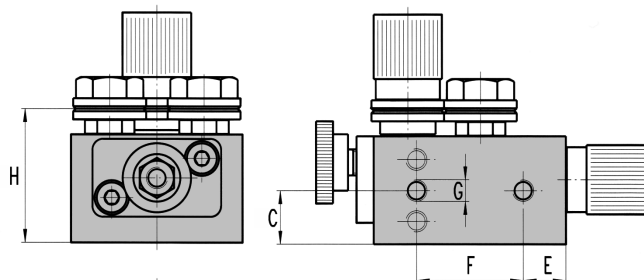
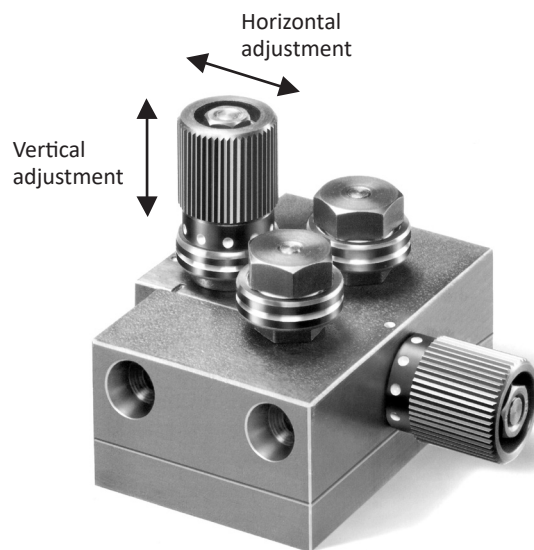

HR Series	Wire Diameter Ranges (mm) $\phi$			
	0 - 0.5	0.5 - 0.8	0.8 - 1.5	1.5 - 3
Order Ref.	HR3-0.5	HR3-0.8	HR3-1.5	HR3-3.0
A	35	40	60	74
B	40	45	55	66
C	12.5	12.5	6 / 24	6 / 15 / 24
D	13	17	23	31
E	10	10	35.5	44.5
F	25	25	N/A	14
G	M5	M5	M6	M6
H	32	31	37	43
L	66	65	98.7	88.5
M	25	28.5	33	35.5
Kg	0.3	0.4	0.95	1.35